



Part Conveyor

High Quality Product for
Coil-Feeding in Press-Room



Simply Profit Maker



JSM PART CONVEYOR

JSM Part Conveyors are simple, compact, modular, accurate reliable pneumatic gadget to remove components, slugs, shavings, punching, scrap from the bottom of the Die. They are beltless conveyors and they transport the pieces with a shaking tray motion. A part customised tray fixed on the standard body with to & fro motion. The linear motion moves tray slowly forward and then quickly backwards. This motion pushes the components & scrap outside Die area into container.

Though it operates on compressed air, the consumption of air is very low and they cost very less compared to
 (a) manual handling and
 (b) motorised belt conveyors.

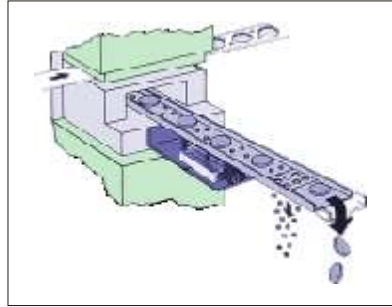

Different type of tray attachments

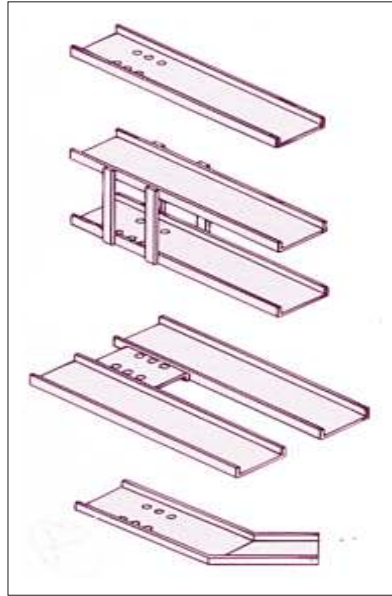

A. Compared to manual unloading it has following advantages

- 1) Safe operations
- 2) Die and operator safety
- 3) Elimination of operator fatigue for removing parts.
- 4) Systematic separation of parts and scraps
- 5) Elimination of sorting of parts/scrap
- 6) Eliminated additional manpower
- 7) Pay-back period is less than 1 year.

B. Compared to motorised conveyors, it has following advantages

Replacement cost of belts, conveyors, bearings, justifies this low cost Part Conveyor on the conventional belt conveyor.

It separates each scrap, part and in larger models two or more customised trays can be used to separate each element coming out from punching. This saves additional investment cost. Two/Three trays in parallel or one above another can separate the element for most cleaner operation.

When to use

There are four major areas where the **JSM Part Conveyor** will outperform a conveyor.

- 1) If there is very little headroom in die
- 2) When working with very thin material
- 3) If the slugs are heavy or sharp
- 4) When die lubricants attack conveyor belts.

Additional Application

Today Part Conveyor is replacing conventional belt conveyor in assembly type operations to move parts.

S P E C I F I C A T I O N S

Model	Load Capacity (Kg)	Line Speed (MPM)	Air Consumption (CFM)	Stroke Length (mm)	Max. Tray Weight Kg	Air Pressure Range (PSI)	Max. Incline of Tray
JSM PC-1	3	7-10	0.5	20	1.5	50-75	8°
JSM PC-2	10	7-10	0.7	20	3.0	50-75	8°
JSM PC-3	20	7-10	1.4	25	10.0	50-75	8°

Technical specifications are subject to change to suit end application.



JAY-SHANTI MARKETING ENTERPRISES

C - 1/A, Kothari Co-op. Soc. No. 3, S. V. Road, Near Tikuji ni Wadi, Manpada, Thane (W) - 400 607.
 Tel: 022-2547 1016, 2547 2029. E-mail : pressroom.india@gmail.com, lajesh@bom5.vsnl.net.in.
 Website : www.powerpressline.net

signsmith/press/0610